

# PENGGOMERSILAN PENYELIDIKAN DAN PEMBANGUNAN (R&D)



**PUTRA  
SCIENCE  
PARK**

**Dr. Mohamad Fakri Zaky Ja'afar  
Deputy Director,  
Putra Science Park, Universiti Putra Malaysia**



**UPM**  
UNIVERSITI PUTRA MALAYSIA  
BERILMU BERBAKTI

# Pengenalan

Dr Mohamad Fakri Zaky bin Jaafar  
Timbalan Pengarah Promosi dan  
Pemasaran Inovasi, Putra Science Park,  
UPM  
zakyjaafar@upm.edu.my



# Engagement

- Training and educating
- Consultancy
- Research and Development
- Know how licensing
- Licensing – outright, exclusive non exclusive
- Expansion

# Why Commercialisation?



- **Total IP > 1900**
- **IP commercialized = 134**
- **Gross Sales > RM 58.91 millions**
- **Income > RM 5.89 millions**



# USA Commercialisation rates

Figure US-8. New Patent Filings and Invention Disclosures Received, 1992–2006

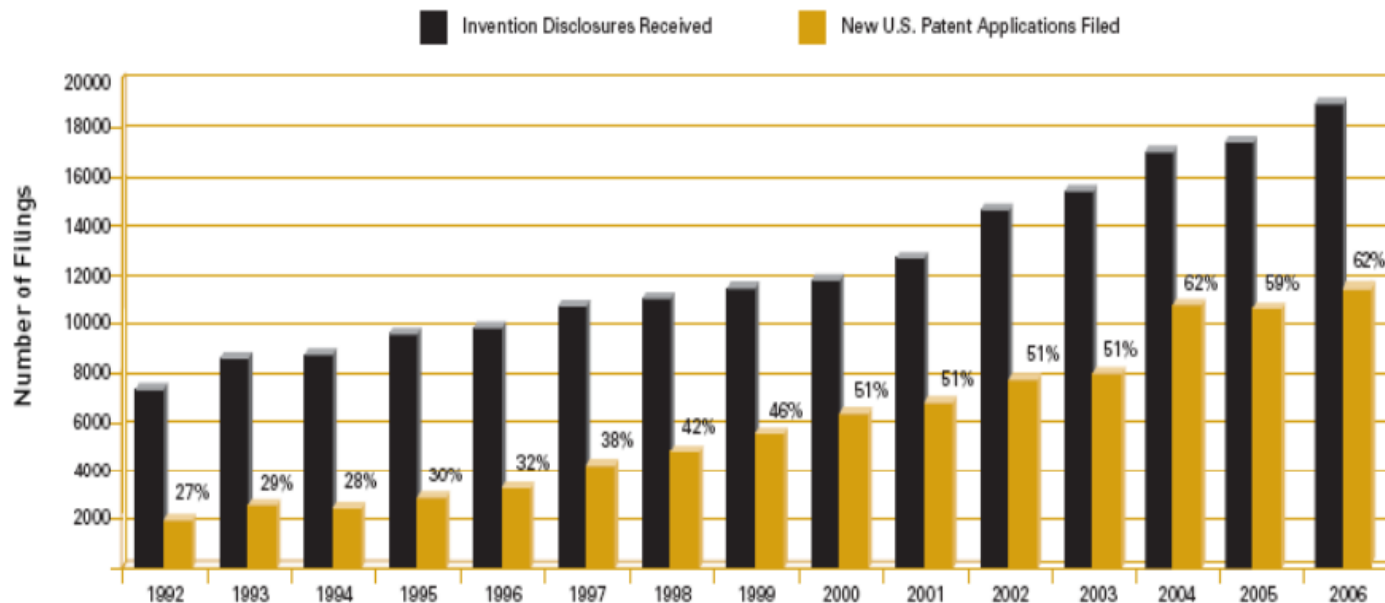

About 10,000 patents granted per year to US universities on about US\$30billion per year research funding ~ \$3M/patent!

# MIT story

**Recent recognition that Patenting & Licensing likely to provide small % of univ research \$ (~4%)**



**MIT among the most successful licensing operation**  
But in 2006 MIT received only \$30M in licensing revenues on a research base of \$1.1B (95% Federal \$)

Research base \$1.1BN (2006)  
Invention Disclosures ~ 523  
Patents filed ~ 321 (of which ~100 granted so far)  
Licenses executed ~ 121  
Start-ups created ~ 23 (eight with equity) ~one per \$50M in annual funding  
Office of 15 licensing professionals

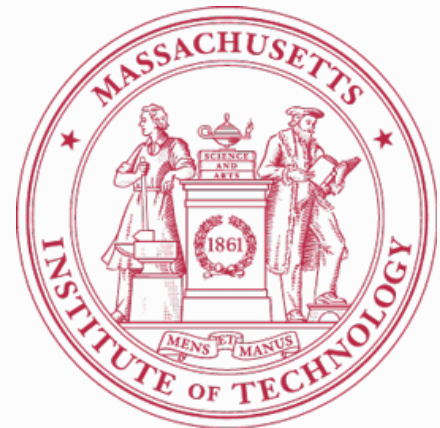

Source: Fiona Murray, MIT sloan school of management

# Rate of licensing revenue over research fund (2008)

Universities	Rate of licensing revenue over research fund
Stanford University	8.7%
<b>University of Massachusetts</b>	6.7%
University of South Alabama	5.9%

[http://www.forbes.com/2008/09/12/google-general-electric-ent-tech-cx\\_mf\\_0912universitypatent\\_slide.html](http://www.forbes.com/2008/09/12/google-general-electric-ent-tech-cx_mf_0912universitypatent_slide.html)



# Total IP filed 2014

	Countries	Total Patent Filed
1	China	928,177
2	Indonesia	8,023
3	Malaysia	7,620
4	Singapore	10,312
5	United Kingdom	23,040

Source: WIPO

# UPM UNIVERSITI PALING INOVATIF NEGARA INI

**Kuala Lumpur:** Universiti Putra Malaysia (UPM) disenaraikan sebagai universiti inovatif terbaik di Malaysia menerusi Reuters Top 75: Asia's Most Innovative Universities, baru-baru ini, berdasarkan kecemerlangan dalam bidang sains, penciptaan teknologi baharu dan membantu memacu ekonomi global.

Menurut kenyataan media dikeluarkan UPM, universiti itu juga menduduki tangga ketiga terbaik pada peringkat Asia Tenggara dan ke-73 di Asia, disusuli Universiti Malaya (UM) di tempat ke-75.



Prof Aini Ideris



REUTERS

Top 75

## Asia's most innovative Universities



# Putra Science Park (PSP)

UPM'S INNOVATION MANAGEMENT CENTER

# PUTRA SCIENCE PARK (PSP)



DIRECTOR  
Assoc. Prof. Dr. Samsilah  
Roslan



IP PROTECTION &  
LICENSING DIVISION  
DEPUTY DIRECTOR  
Dr. Zahira Mohd Ishan



INNOVATION  
PROMOTION &  
MARKETING DIVISION  
DEPUTY DIRECTOR  
Dr. Mohd. Fakri Zaky  
Jaafar



EDU-PARK DIVISION  
DEPUTY DIRECTOR  
Assoc. Prof. Dr. Faridah  
Qamaruz Zaman



CEO OF  
COMMERCIALISATION  
Mr. Ahmad Zakir Dato'  
Wira Ja'afar

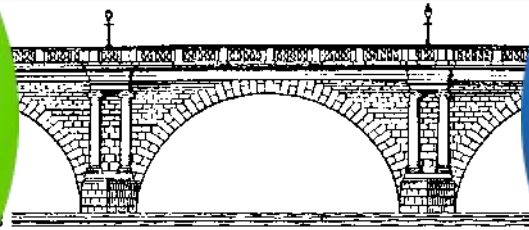

# **Innovation Management Office (PSP)**

*- Technology Transfer Office (TTO),  
Technology Licensing Office (TLO)*

Researcher

**INNOVATION**



IP Protection Division

**IP PROTECTION**



Innovation Promotion & Marketing Division

- **PROMOTION & MARKETING OF IP (DESIGN & CONCEPTUAL PROTOTYPE)**
- **COLLECTS FEEDBACK FOR MARKET SURVEY & STRATEGIC PLANNING**



Technology Transfer Unit, PSP Director's Office

**BUSINESS MATCHING,  
NEGOTIATIONS &  
TECHNOLOGY TRANSFER**

Edu Park Division

**SHOWCASE  
VIA EDUTOURISM**

InnoHub Unit,  
PSP Director's Office

**BUSINESS  
INCUBATOR  
(MARKET  
VALIDATION HUB,  
COMMERCIAL  
READY  
PROTOTYPE)**

# Main challenges

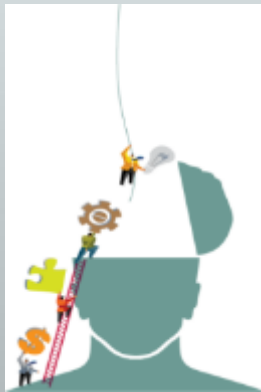

**Early commercialization & Funding Issues**

**Industry-Academia Engagement at Ideation Stage**



**SMEs issues**



**Large Corporation Issues**



**Valley of Death**

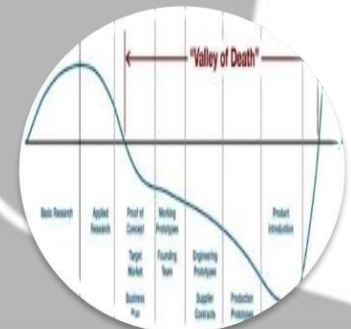



# Pengkomersialan di UPM

- UPM mempunyai Ekosistem pengkomersialan inovasi yang menyeluruh – terbaik di Malaysia.
- Merangkumi
  - Penyelidikan
  - Perlindungan harta Intelekt
  - Promosi
  - Perundingan perlesenan, JV
  - Pembangunan perniagaan – startup -Innohub



## ITMA

Innovation &  
Technology Managers  
Association

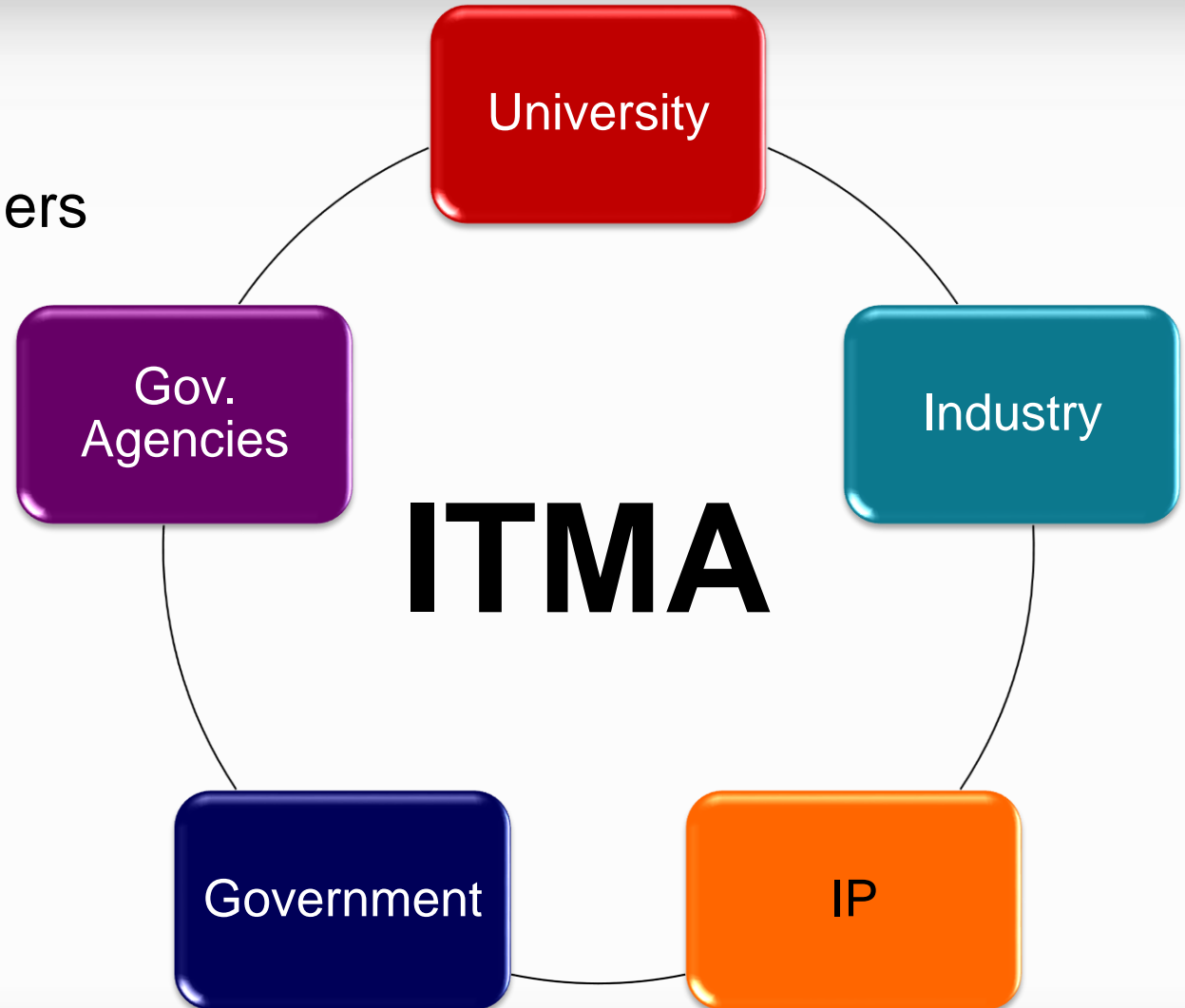

*"If you do not seek out allies and helpers, then you will be isolated and weak." - Sun Tzu, "The Art of War"*

## **Innovation Champion Network**

- To raise Innovation champions from each faculty
- To provide innovation training for ICs
- To discover and inspire innovation at Faculty / Institute level

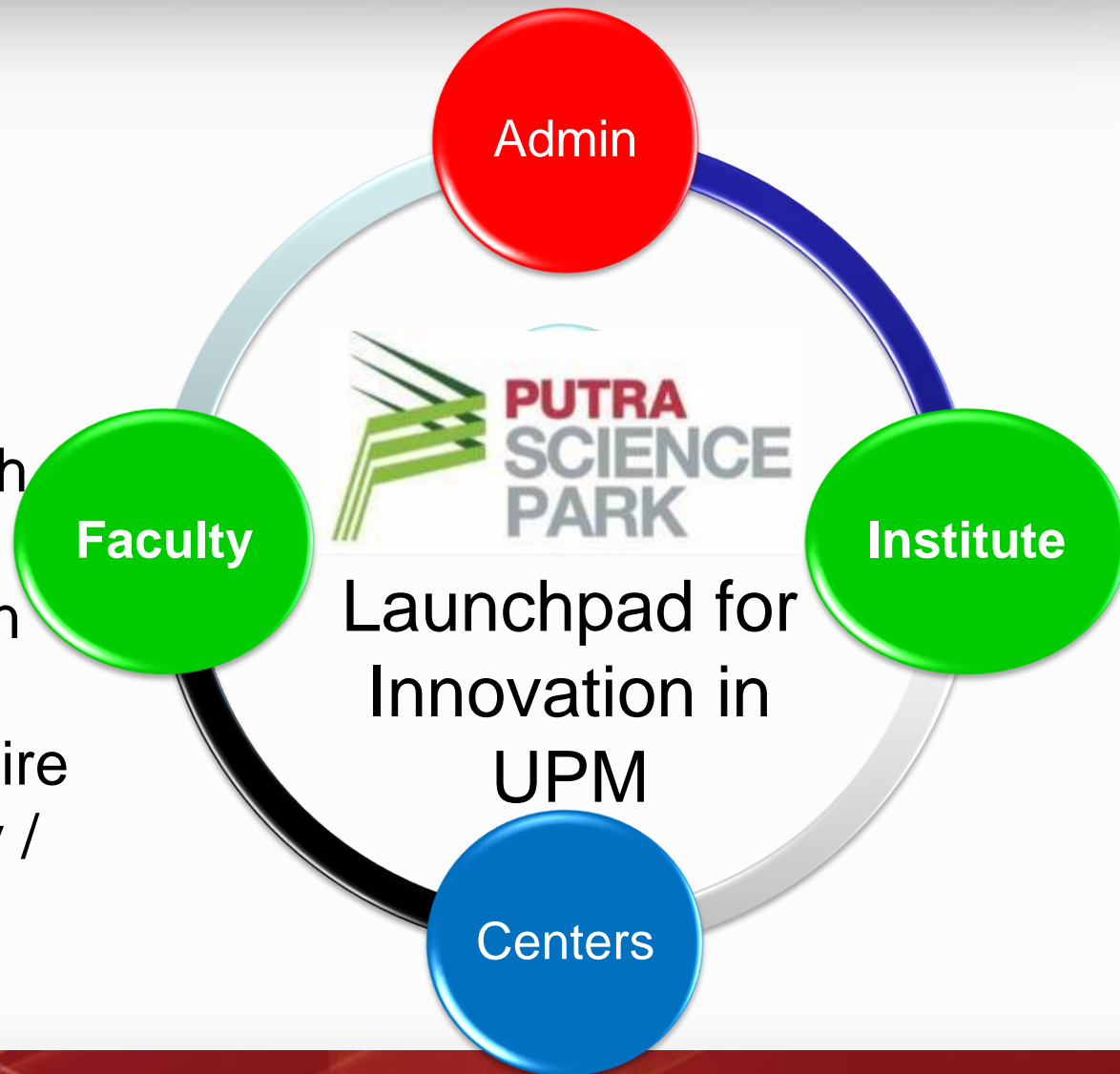

# Promotion channels



**WEBSITE**



**EXHIBITIONS**



**PRESS  
RELEASES**



**PRESS  
CONFERENCES**



**IOD (INNOVATION  
SHOWCASE & BUSINESS  
MATCHING SESSIONS)**

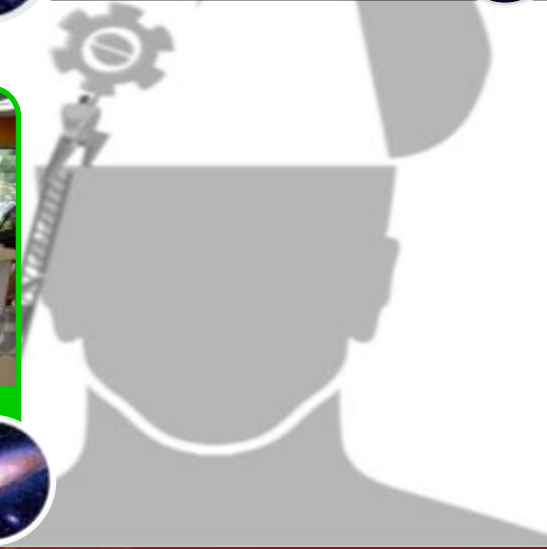

# MASS MEDIA



# MEETING WITH INDUSTRY

- Industry contact promotion office from media and other promotional channel
- Engage researcher to explain tech, nda might be necessary
- Few meetings, then proceed to tech transfer division





INNOVATION OPEN Day

**Objectives**

## PROSPERING THROUGH INNOVATION

UPM Innovation Open Day is a promotional commercialisation event showcasing innovations and expertise of each faculty and institute of UPM







**A = Cost to produce IP by Industry**

**B = Cost to produce IP by University**

$A < B$  : Not worth taking up

$B < A$  : Worth taking up

$A = B$  : Discuss / Negotiable –  
WHAT ARE THE ADVANTAGES?





**PRODUK2 YANG TELAH  
BERJAYA DI KOMERSIALKAN**





**UPM**  
UNIVERSITI PUTRA MALAYSIA  
BERILMU BERBAKTI

# Agricultural Products

Berilmu Berbakti With Knowledge We Serve



**Fowl Pox Vaccine**

**RM 2.86  
million**

**Newcastle Disease Vaccine**

**RM 1.33 million**

**Infections Bursal Disease  
Vaccine UPM93 Strain**

**RM 1.07 million**

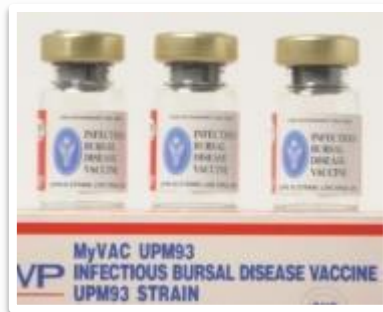

Vaccines in the  
poultry industry



**MVP**  
MALAYSIAN  
VACCINES AND  
PHARMACEUTICALS  
(CO NO: 82381-X)

*Dilesenkan kepada :*  
**Malaysia Vaccines & Pharmaceuticals  
(MVP)**



**UPM**  
UNIVERSITI PUTRA MALAYSIA  
BERILMU BERBAKTI

# Agricultural Products

Berilmu Berbakti With Knowledge We Serve



**ZAPPA®** -The rice seeds germination enhancer

*Patent -MY133162A*

**RM 26.5**

**million**

**Vita-Grow®** - The growth and yield enhancer

*Trade Secret*



*Licensed to:*

**Diversatech (M) Sdn.**



**UPM**  
UNIVERSITI PUTRA MALAYSIA  
BERILMU BERBAKTI

# Agricultural Products

Berilmu Berbakti With Knowledge We Serve

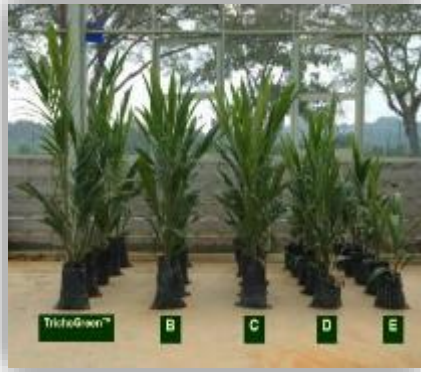

**Trichogreen™** - a biocontrol agent and growth enhancer for oil palm industry

*Trade Secret*

**RM67,000.00**

**Unique Nutrients Sdn. B**



**UPM Bacto-10 - Biofertilizer**

*Trade Secret*

**\*RM 100,000**

**PhytoGold Sdn. Bhd**



**UPM**  
UNIVERSITI PUTRA MALAYSIA  
BERILMU BERBAKTI

# Agricultural Products

Berilmu Berbakti With Knowledge We Serve



**Pneumonic Mannheimia Vaccine** - vaccine for goats and sheep against mannheimia haemolutica infection

*Patent - PI20070305*

**\*RM 4 million**

**ST Biolife Sdn. Bhd.**



## **KUSTEMVax**

Mannheimiosis vaccine - an intranasal spray vaccine for sheep and goats

*Patent - PI20060550*

**RM100,000**

**Joint owner with UMT  
Profound Vaccine Sdn. Bhd.**



**UPM**  
UNIVERSITI PUTRA MALAYSIA  
BERILMU BERBAKTI

# Agricultural Products

Berilmu Berbakti With Knowledge We Serve



**Monogastric Animal Feed** – a  
feed additive or food supplement  
formulation

**\*RM 1 million**

*Patent - PI201005787*

**Nu-Trino Synbio (M)  
Sdn Bhd**



**StellarLac** -  
Probiotic for chicken

*Trade Secret*

**RM 200,000**

**Janaf Sdn. Bhd.**



**UPM**  
UNIVERSITI PUTRA MALAYSIA  
BERILMU BERBAKTI

# Agricultural Products

Berilmu Berbakti *With Knowledge We Serve*

## Machines for Small and Medium Entreprises (SMEs)



Rolled  
Tart  
Machine



Multi - Ezy  
Cutter



Coconut Auto  
Squeezer  
Machine

Tuberous  
Fruits &  
Vegetables  
Shredding  
& Slicing  
Machine



Pineapple  
Multi-  
Peeler  
Plus



Ezy  
Cooker







**Soil Prop** – Soil Property Calculator - machine that measures soil properties

*Copyright*

**Pidmams Smartfarming  
Sdn. Bhd**



**Development and Production  
of Shrimp Feed** – probiotics for shrimps

*Know-how technology*

**Neuriech Feedmill Sdn. Bhd.**



Berita - Baka baru  
ayam kacukan UPM  
mampu bertelur  
empat kali ganda  
setahun

- Menghasilkan 120 hingga 200 biji telur setahun
- Telur lebih besar, 60 gram sebiji berbanding telur ayam kampung biasa 45 gram
- Tempoh pembesaran lebih singkat tidak melebihi 13 minggu
- ayam seberat 1.2 hingga 1.4 kilogram seekor.
- menguntungkan untuk aktiviti komersial kerana boleh dipasarkan lebih awal.

**Ayam AKAR PUTRA**

**Mannhemia haemolytica bacterial polypeptide and sequences, gene sequences and uses thereof**

**RM 300,000**



**RM 100,000**

**An improved sterilization process to increase palm oil extraction rate**

**Stone Mastic Asphalt (SMA) : safer road surfaces**

**RM 50,000**



**RM 50,000**

**Real Time Oil Palm Fruit Grading System : Fresh Fruit Bunch (FFB) Hyperspectral Scanner - fruit maturity detection and classification**

**RM 50,000**

**TQRF (THYMOQUINONE Rich Fraction) as  
Cardioprotective and Neuroprotective Agents**



**AFLOK : A Method For Producing A  
Biopolymer**

**RM 10,000**

**Perisian Fonik, Tutor untuk Murid-murid  
Disleksia Visual : diagnostic tool and software  
as language therapy in Bahasa Melayu**



**RM 50,000**



**Integrated Production of High  
Performance Biolubricant From  
Renewable Resources**

**RM 10,000**

**PROMOLAKTIN: Composition for promoting lactation with tumour suppressive properties and preparation method thereof**

**RM 2,000**

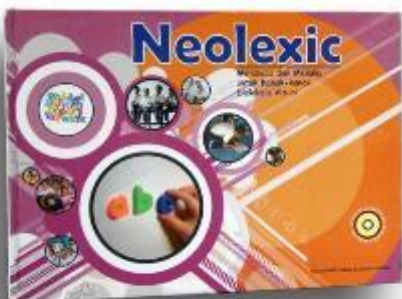

**NEOLEXIC: Membaca Dan Menulis Untuk Kanak-Kanak Disleksia Visual**

**RM 1,250**

**3D Facial Expression Database**

**RM 500**



**Development and Production of Shrimp Feed**



**Polytop**



**Bioencapsule and Method Thereof**



**Porous Bioceramic Composition for Bone Repair**





HaFYS dan sistem PCR GeneSTAT dibangunkan pada 2009 dan dipatenkan pada 2011 serta dilesenkan secara eksklusif kepada DxNA LLC, sebuah syarikat berpangkalan di Amerika Syarikat untuk pasaran luar negara.

# Halal detection kit: Kes Hujan Emas di Negeri Orang

Nurturing startups..

# **INNOHUB PROGRAM**

# Lembah Kematian – Valley of Death

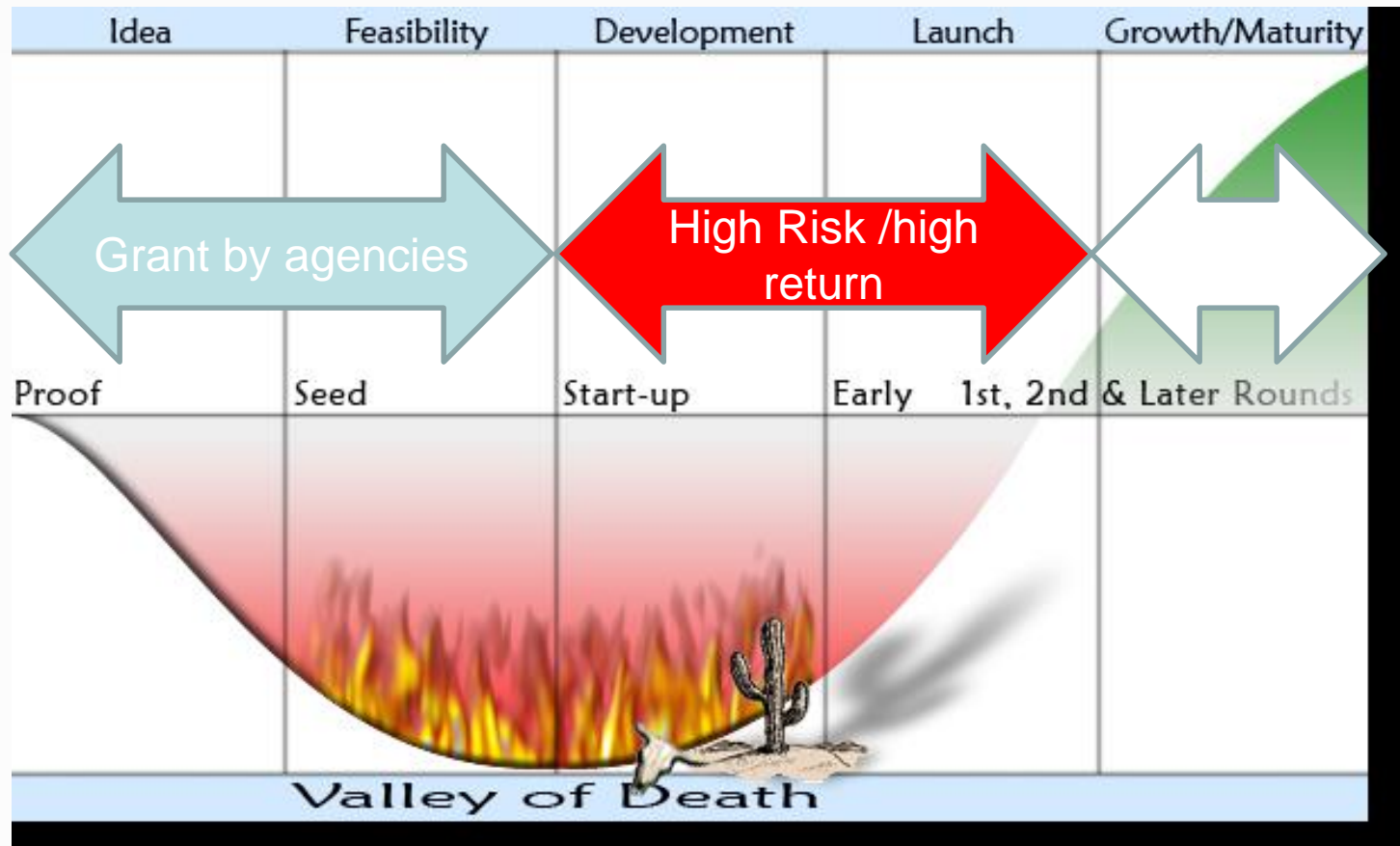



# Challenges for commercialising innovation

- Innovation need upscaling, high capex.
- Payback will only start 3-5 years onwards
- Malaysian VC and ANGEL industries are still risk averse
- Grants will provide assistance but to certain extend. It creates crutch dependency which will not prepare business for real market scenario.
- 9 out of 10 startups fail
- Some of factors of failure due to wrong market assumptions, cost assumptions, supply assumptions.  
World trend assumption
- Hence need market validation

# INNOHUB PROGRAM

## INNOHUB – Nurturing Startups, straddling valley of death

- 2014 – 19 startups
- Researcher as shareholder
- Internal grants of 100k
- Salary Project Manager, market validation study
- To validate business proposal assumption – demand, cost, supply, market segment as well as promotion
- 2016 – secured > RM 4,000,000 precomm funding from various agencies, Platcomm, Teraju, etc.
- 2016 – 20 more startups



# INNOHUB PROGRAM



- Mentoring, coaching, networking and pitching.
- Sometime sales already secured during validations phase.
- 2017- 5 startups to graduate.
- 2017 – Putra Science Park helps setting up INNOHUB for MARDI

## RNZ LIPASE & RNZ PROTEASE



➤ Zymeratics is a Malaysian-grown customized enzyme boutique manufacturer that produces high quality enzymes for various industrial applications

➤ Total investment: **RM1.3**





RJ  
MACHINE  
SOLUTION  
SDN BHD

## PEPPER PEEL-O-MATIC

PEEL-O-MATIC is a pepper decorticator machine that can reduce the number of production days for white pepper by 50% and at the same time replaces human intervention with its adoption of rubbing, cleaning and sieving mechanism in the machine.

- TOTAL ORDERS TO-DATE : 2 units awarded to 2 longhouse community in Betong, Sarawak (largest White Pepper production area in Malaysia) under the Rural Transformation Program



## Hydroponic Rack

- Is an indoor hydroponic system that was designed to meet the needs and inspiration of urban agro polis lifestyle. The product adopting a modular system concept that can be assembled and disassembled easily by any user.
- Total Order in industrial scales : Over 300
- Total investment: **RM 500,000**





PAKAR GO GREEN SDN. BHD.

## Biomass Microwave Carbonizer (BMC)

- Using microwave energy to burn biomass to biochar with at least 50% faster burning than conventional method.
- 89.6% cleaner burning than the coal's medium-high grade



eni



## THOHIRA

"Thohira" is a registered trademark of UPM. Thohira Aquaformula contains a special blend of ingredients that promote good health and growth of aquatic organisms especially fishes. These ingredients are sourced locally and the sustainable and economical production is ensured. Other key features of Thohira are capability to improve water quality as well as ~~to be environment friendly~~. : **RM**

**174 000**





# STAR KIT

## Story Telling

### Augmented Reality Kit

A two-way interactive educational tool with books and boards using Augmented Reality technology via engagement features patented in the NEMD (Norma™ Engagement Multimedia Design) Model.



# PUTRA DYNAMIC



- **Putra Dynamic**, a training section within Putra Science Park, UPM
- **Putra Dynamic** provide series of training and awareness of the whole process of innovation, right from inception of inventive ideas, IP protection through to successful commercialisation.

# Our Achievement

## Collaboration with SRI International

- ✓ SRI International: 5 Disciplines of Innovations (5DOI)
- ✓ SRI International: Entrepreneur Leadership Training (ELT)
- ✓ SRI International: Venture Plan Essentials Boot Camp
- ✓ SRI International : Program Value Creation Advisor



## Collaboration with Suruhanjaya Syarikat Malaysia

- ✓ Corporate Directors Training



## SEAD- Patent Drafting Course

- ✓ Preparation for national and European Patent Drafting Examination



## Intellectual Property Awareness Workshop – Politeknik Shah Alam



## Training for the Leaders of Technology Transfer Centers

- Collaboration with AKEPT



## Seminar Inovasi dan Harta Intelektual

- Collaboration with FELDA
- 6 Wilayah



## Seminar on Hands on Industrial Design – Politeknik Shah Alam



## Workshop on Lean Market Validation – Universiti Teknologi Petronas



# Intellectual Property

- Patent
- Industrial Design
- Copyright
- Trade Secret
- New Plant Variety

These need to be protected for higher chance of commercialization.



So what is innovation

# A story



8,000,000.00 dolar



20.00 Dolar

# Adik Beradik Wright – Kapal terbang

- 1903, berjaya membina kapal udara yang berkuasa menerbangkan manusia.
- Walaupun banyak perekacipta lain mengusahakan kapal udara yang berkuasa, Inovasi utama ialah **SISTEM KAWALAN PEMANDUAN PENERBANGAN SELAMAT.**

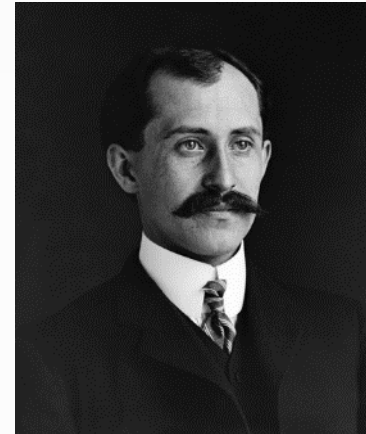

# Alexander Graham Bell

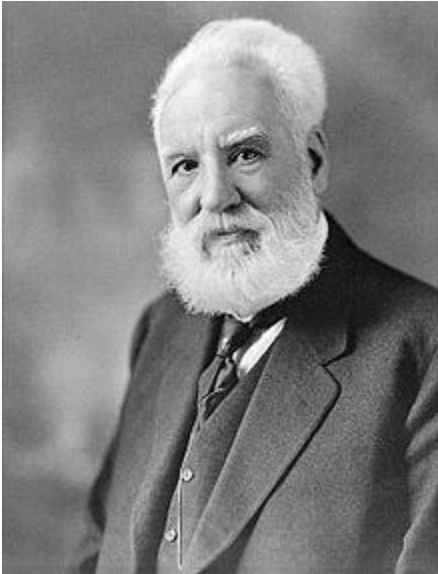

- Berminat dalam peralatan bantuan pendengaran kerana ibu dan isteri yang mengalami masalah pendengaran.
- Mencipta telefon pertama dan menawarkan paten kepada western union sebanyak USD100,000 tapi ditolak kerana dianggap hanya mainan
- Terbukti Beliau sendiri menjadi jutawan dengan inovasi telefon ini.

## Thomas Edison (1847-1931)

- Lampu mentol filamen
- Gagal setelah mencuba beribu kali
- Menganggapnya bukan kegagalan, tetapi menemui seribu satu cara untuk tidak melakukannya.
- Antara yang pertama mewujudkan pengeluaran kilang dan pasukan yang besar untuk sesuatu inovasi

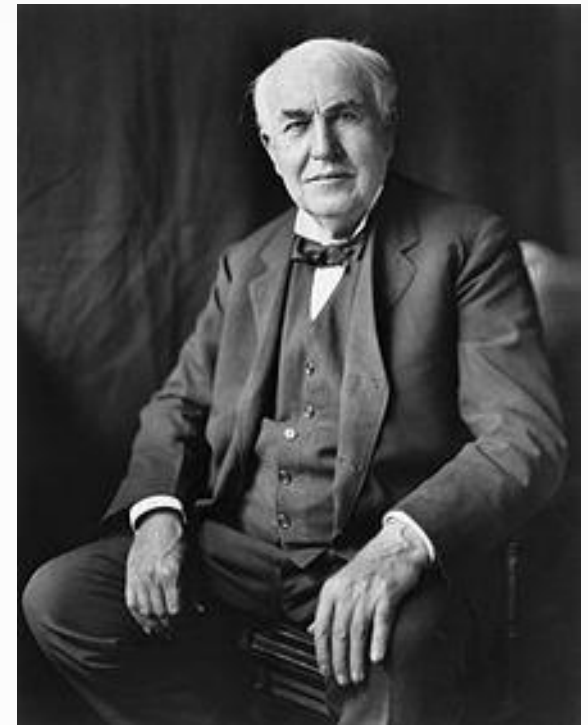

# Innovation – The Fosbury Flop



# Innovation in Architecture

## Innovation

### Eco-Friendly Insulation Offers Thermal Performance, Sound Absorption and Fire Resistance at the Same Time

14:00 - 25 February, 2018



### 9 Innovative Projects Tackling the Unexplored Realms of Sea and Space Win Jacques Rougerie Competition

13:10 - 31 January, 2018



# Innovation in Architecture

## Innovative 'Wooden Bricks' System Cuts Building Time to Just a Few Days

08:00 - 26 January, 2018



## Open Call: Wanted. Radical Ideas about Houses and Housing

13:12 - 28 November, 2017

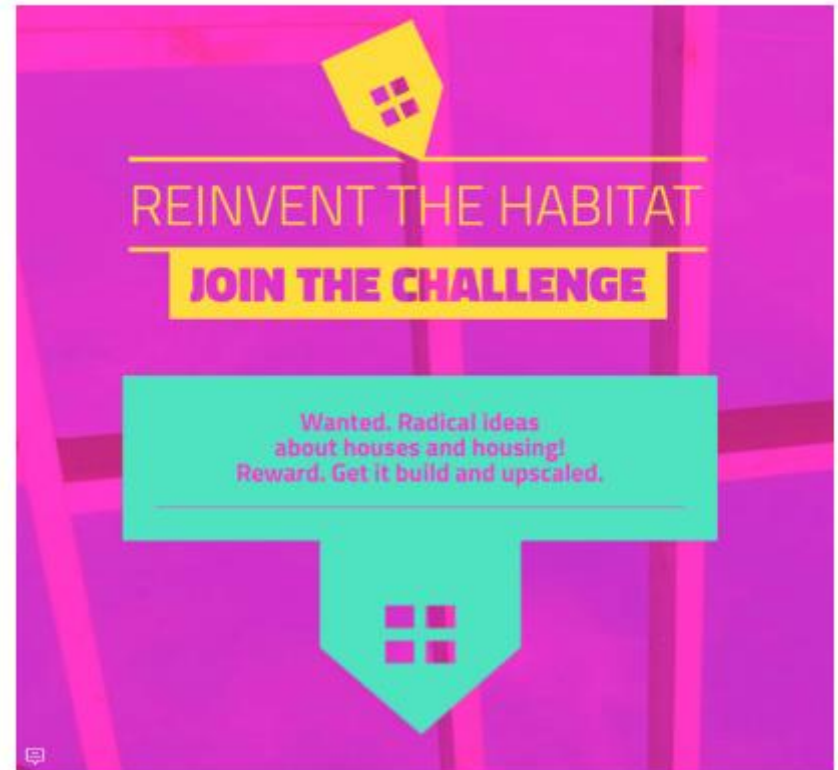



# Innovation in Architecture

- The Segal Method



# Innovation in Architecture

- Buckminster Fuller

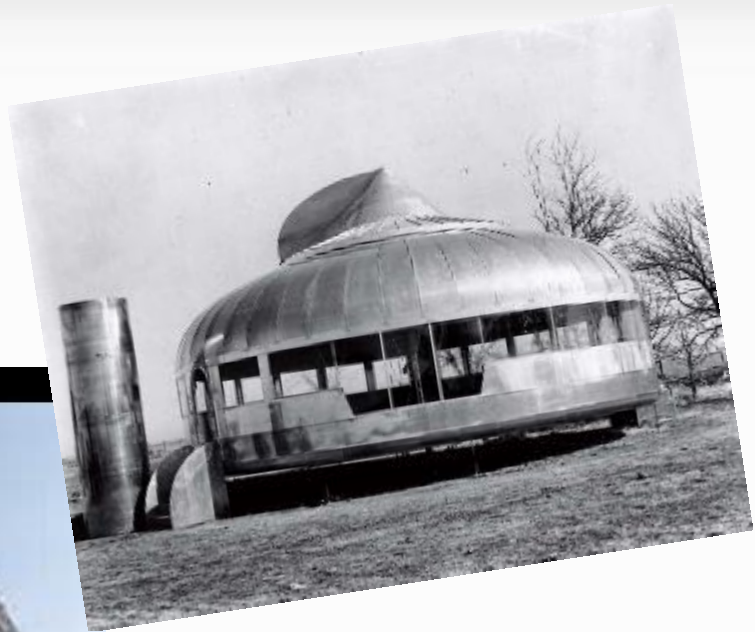
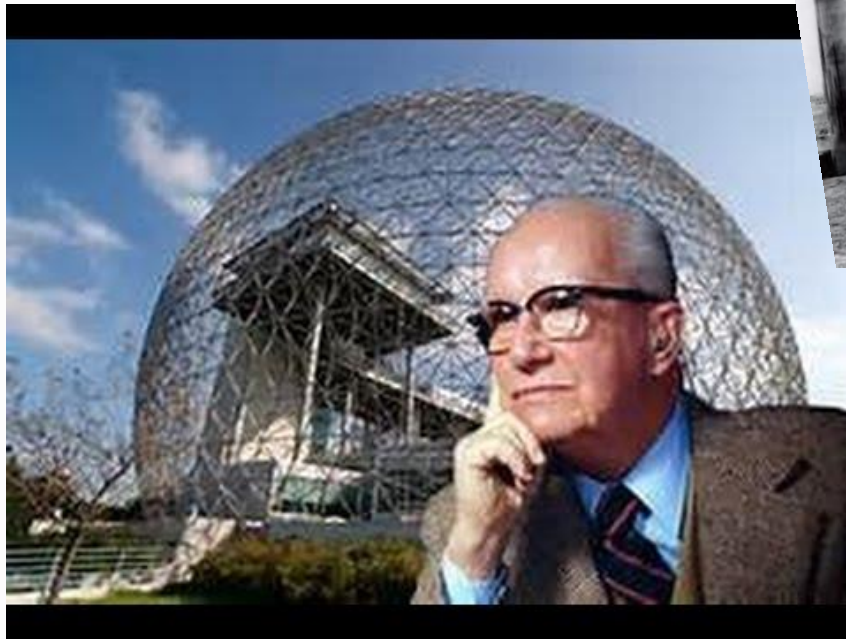

# UPMs PUTRA BLOK - *FEATURES*

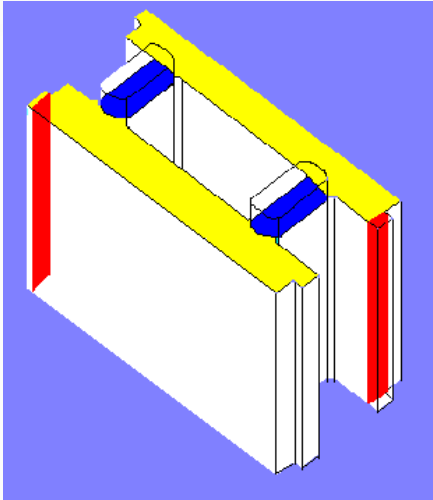

**STRETCHER BLOCK**



**CORNER BLOCK**



**HALF BLOCK**



# Failed Innovation



# Valley of Death

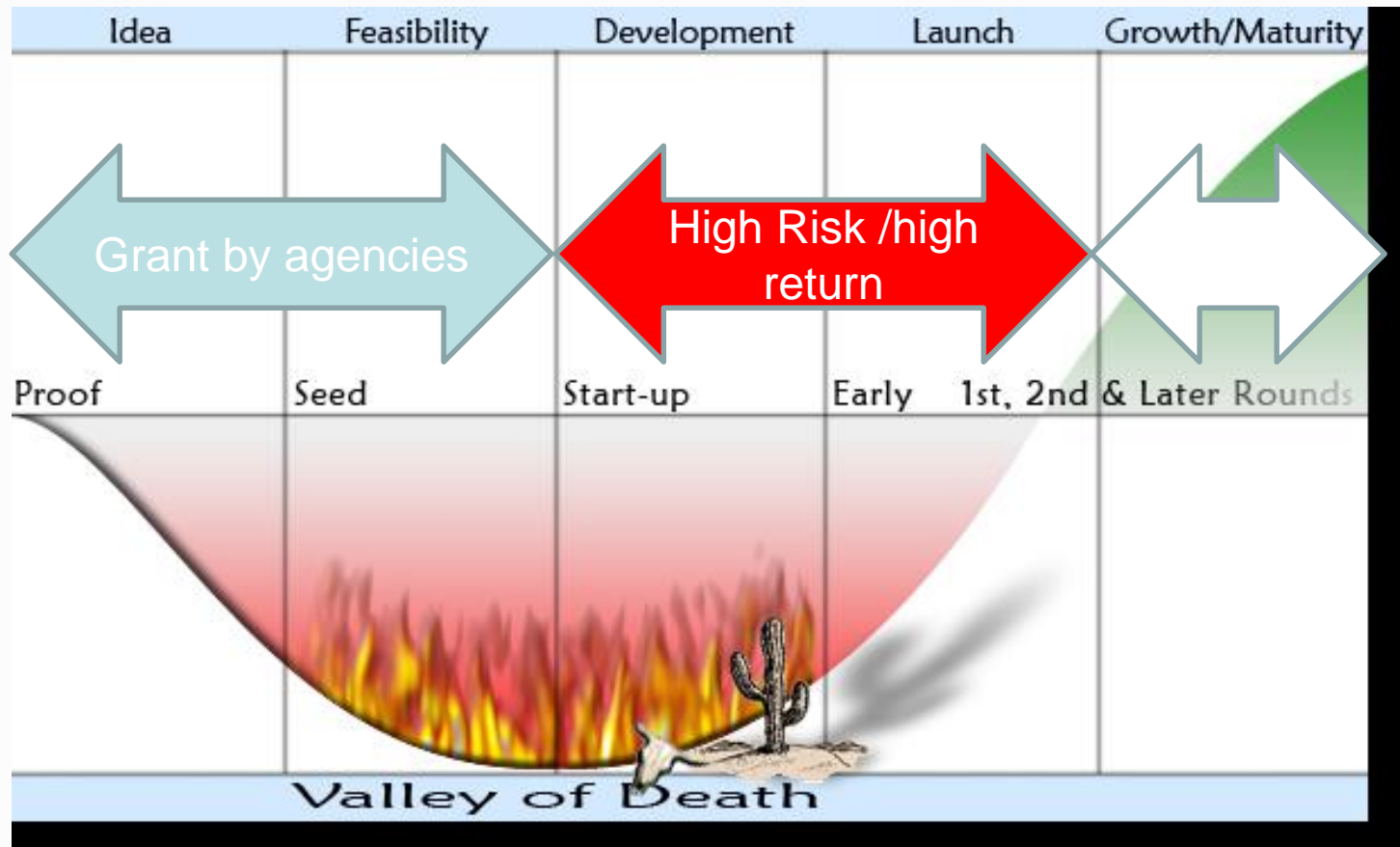

# Learning from the best

- Computer mouse
- Internet designation .com, .org
- Wireless communication
- Check number identification
- HD Tv, (won emmy award)



# 5 Discipline of Innovation

- 1.IMPORTANT NEEDS
- 2.VALUE CREATION
- 3.INNOVATION CHAMPION
- 4.INNOVATION TEAMS
- 5.ORGANISATIONAL ALIGNMENT

## DISCIPLINE 1 : IMPORTANT NEEDS





## DISCIPLINE 2 : VALUE CREATION

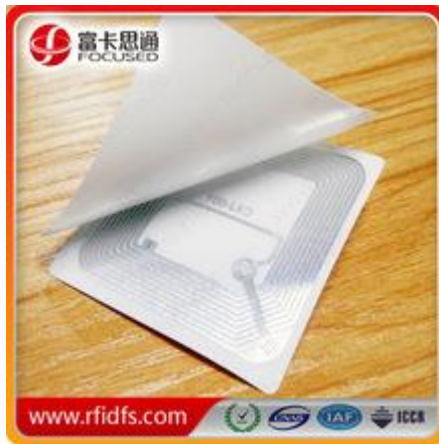

## DISCIPLINE 3 : INNOVATION CHAMPION



## DISCIPLINE 4 : INNOVATION TEAM

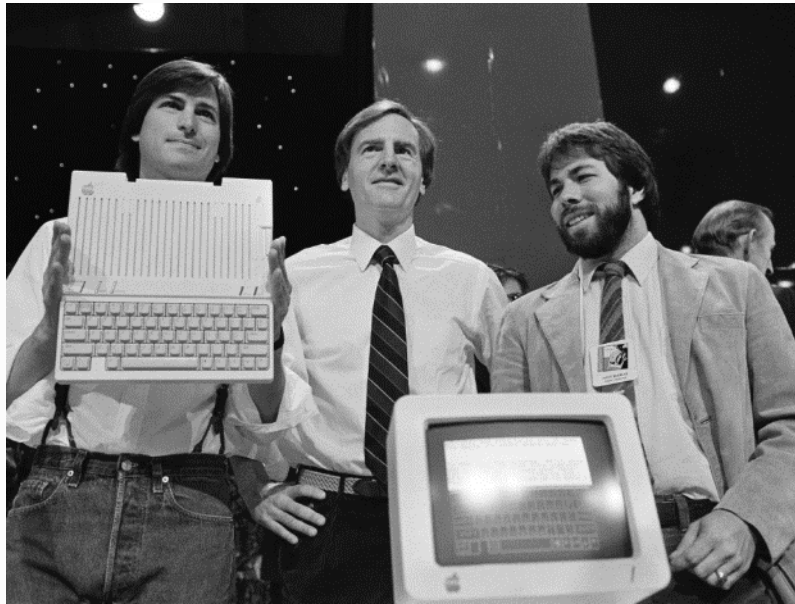

## DISCIPLINE 4 : ORGANISATIONAL ALIGNMENT



# NABC Method

- Pitching method
- Elevator Pitch
- Consists of:
  - **Hook**
  - **N-Need**
  - **A-Approach**
  - **B-Benefit per cost**
  - **C-Competition**
  - **Closure**
- To start you need a **Hook**, to end you need to state your **Closure**

# Group Work

- Work in a group of Six;
- Identify an innovative solutions for students need in UPM
- Present your innovation in 5 minutes NABC pitch to 4 groups of people who will be wearing:
  - Green Hat: Always give positive feedback only
  - Red Hat: Always give negative feedback only
  - White Hat: The Investor, with the money to give but the cost to worry with
  - Blue hat: The end user, the students of FRSB.

# LESSONS LEARNT

# LESSONS

- R&D Side:
  - Research not relevant to market and societal need,
  - Fundamentals need long jumps before becoming a market offering
  - Researcher overwhelmed by R&D, not willing to engage with industry
  - Publish or protect?



# LESSONS

- University side:
  - Not structured for commercialisation
  - Agreement took too long
  - Legal has to protect academic integrity and raise issues sometimes hindering dynamicity of commercial exercise
  - Holdings has to protect interests of shareholder to max profit, commercialising innovation is risky

# DIFFERENT EXPECTATIONS

## Industry perception

- University charge expensively
- Too much beureaucracy
- Slow in processing engagement
- Academics don't understand business dynamics
- Most of the researches are too raw and has long way to go before it can go to the market.
- IF we give the fund, you should do it as we say.
- Why are they 'syok sendiri' with their technology? WHO wants them?

## University perception

- Business want things free
- They don't understand the diligence of research and hence tend to rush things.
- Expect Innovation are ready to be mass produced.
- Malaysian business are risk averse and not psyched to embark on innovation business
- Industry rely to much on commercialization grant from the government

## Paradigm Shift in the university

- Need to focus on market needs: 5 disciplines of Innovations, focusing on real significant needs. PPRN Initiatives to overcome this
- Processing protocols and process need to be minimized
- Proactive promotion and marketing
- Strong IP protection and management



**UPM**  
UNIVERSITI PUTRA MALAYSIA  
BERILMU BERBAKTI

*Thank You*  
*Terima Kasih*